



AyudasDinámicas®

Productos para una mayor independencia

Sillón Elevador Dune

ref: AD763

<https://www.ayudasdinamicas.com/index.php/p/sillones-basculantes-y-elevadores/sillon-elevador-dune>



Sillón relax eléctrico tapizado en un tejido de poliéster efecto piel. Lleva sistema Power Lift, un mecanismo articulable que levanta verticalmente el sillón para permitir a la persona a levantarse con mayor facilidad. Incorpora dos motores que hacen que el movimiento del respaldo y del reposapiés articule de manera independiente. Se acciona con un mando.





Ayudas Dinámicas®

Productos para una mayor independencia

Peso máximo: 100 kg

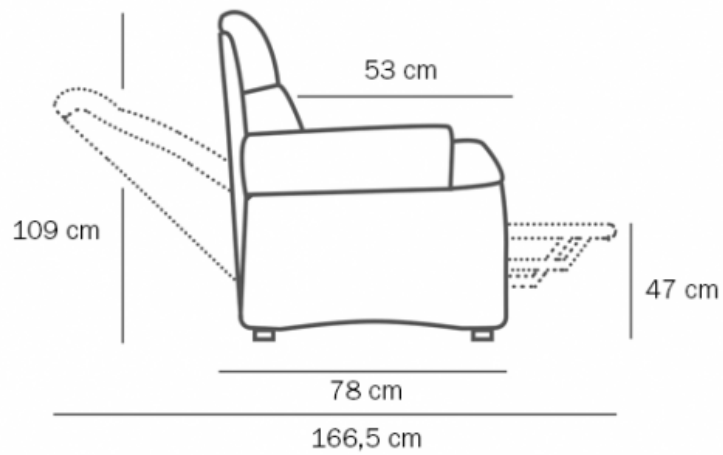

Máximo
100



Montaje sin
herramientas

